



BRICKING SOLUTIONS[®]

A DIVISION OF BROKK

FORK TRUCK BRACKET - PART NUMBER ASM740

Specially designed carrying bracket for carrying a complete Bricking Machine arch or set of scaffold frames in and out of the kiln or around the plant with a fork truck.

Your assembled Bricking Machine arch is lifted straight up from its storage location and rotated 90 degrees so that the ring rides parallel with the fork truck through the plant and up the kiln. At the scaffold, the ring is raised and turned on the bracket into the proper installation position. The unit is then lowered onto the base plates and bolted into place. The use of The Fork Truck Bracket enables the ring and scaffold frames to be moved without being disassembled - saving time during each use

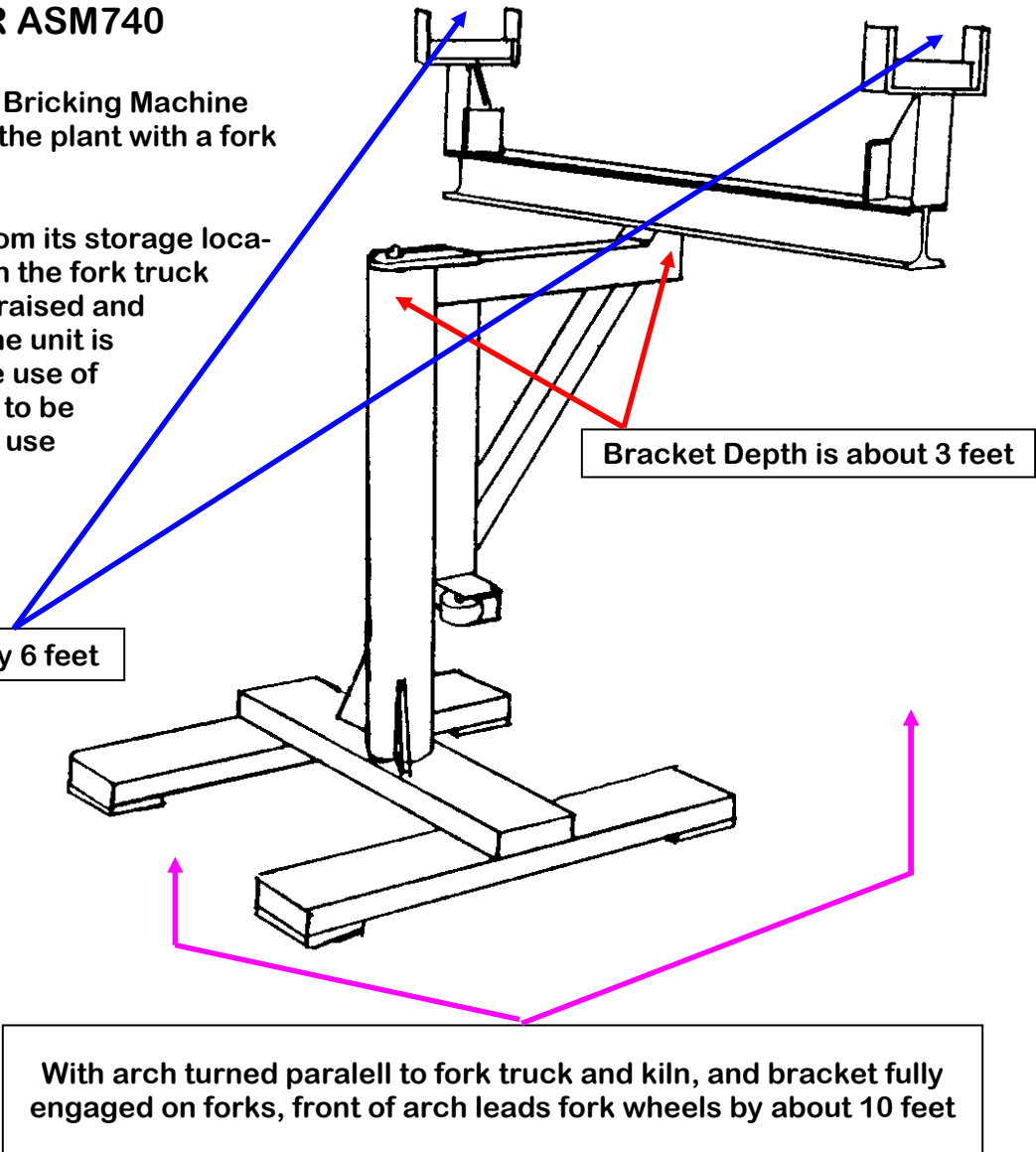
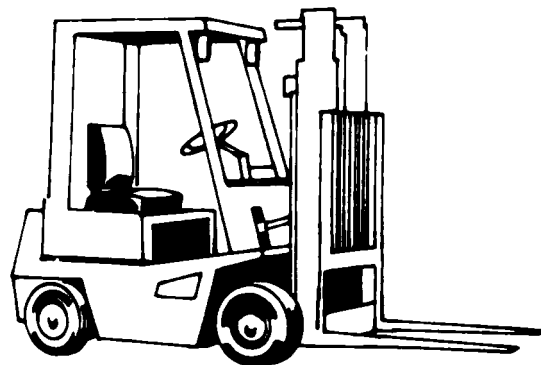

1144 VILLAGE WAY • MONROE, WA 98272 • USA
800.621.7856 • 360.794.1277 • FAX: 360.805.2521

WEB: WWW.BRICKINGSOLUTIONS.COM / E-MAIL: INFO@BRICKINGSOLUTIONS.COM